

3G Cellular

Telecommunication Market Evolution — 1

Late 20th century

Voice traffic >> data traffic

Data traffic over analog / digital voice infrastructure

Access

V.35 / ADSL modem over telephone local loop

Backbone

Routers / switches on leased telco trunk lines

Separate PSTN and cellular networks

Cellular backhaul

PLMN infrastructure on leased telco trunk lines

Most profitable market sectors

PSTN

Long distance voice calls

Cellular

Air time

Telecommunication Market Evolution — 2

Early 21st century

Voice traffic < data traffic

Integrated networks — voice / data + fixed / mobile

IP over voice infrastructure → Voice over IP (VoIP)

Most profitable market sectors

PSTN

Leasing lines for data infrastructure

Cellular

Messaging, ring tones, multimedia services

Implications for Third Generation

System goals

Global mobility

Wide range of services

Voice telephony

Messaging + paging

Internet (WWW + email) access

Broadband data transport

Gateways among incompatible radio systems

More flexible PLMN routing infrastructure

Migration paths

TDMA d-AMPS → retirement

GSM → UMTS

More efficient radio spectrum utilization (CDMA replaces TDMA)

CDMA → cdma2000

More efficient radio spectrum utilization (higher capacity CDMA)

3G Standardization

Internal Mobile Telecommunications (IMT-2000)

International Telecommunications Union (ITU) standards for 3G
 Defines multiple competing (incompatible) systems

Universal Mobile Telecommunications System (UMTS)

GSM/GPRS replacement using CDMA radio interface
 Third Generation Partnership Project (3GPP)
 Consortium of manufacturers (www.3gpp.com)

CDMA 2000

CDMA replacement using cdma2000 radio interface
 Third Generation Partnership Project 2 (3GPP2)
 Consortium of manufacturers (www.3gpp2.org)

WiMAX

Broadband wireless data access using cellular technology
 WiMAX Forum
 Consortium of manufacturers (www.wimaxforum.org)

UMTS

Physical layer

User access: GSM TDMA → W-CDMA or TD-CDMA
 Similar to cdmaOne and cdma2000 but not compatible
 Different frequency bands
 Different pseudorandom noise (PN) coding scheme
 Circuit mode data rates up to 1.92 Mbps
 144 kbps and 384 kbps on high-utilization systems

New PLMN node definitions

BSS (base station subsystem) → RNS (radio network system)
 BSC (base station controller) → RNC (radio network controller)
 BTS (base transceiver system) → Node B

Protocols

New internal network operations
 Frame Relay in backbone infrastructure → ATM

UMTS Radio Bands

W-CDMA

Frequency Division Duplex (FDD)

60 MHz uplink band 1920 – 1980 MHz

60 MHz downlink band 2110 – 2170 MHz

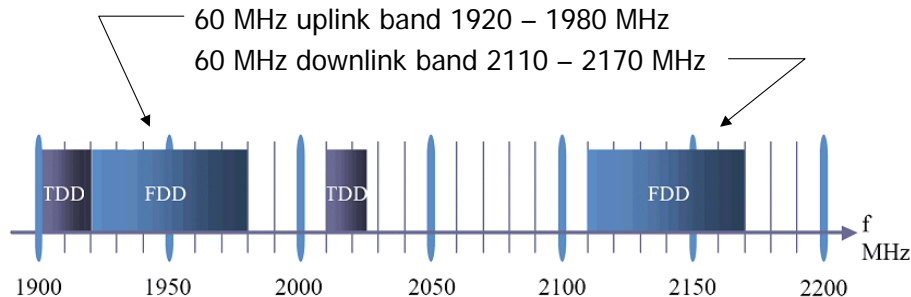

TD-CDMA

Time Division Duplex (TDD)

15 MHz timeshared uplink / downlink band

1900 – 1920 MHz + 2010 – 2025 MHz

W-CDMA

Frequency division duplex (FDD) method

Similar to cdmaOne

60 MHz **UPLINK** band and 60 MHz **DOWNLINK** band

Divide 60 MHz radio bands into 4.4 to 5 MHz RF channels

UE allocated uplink frequency and downlink frequency

CDMA

User allocated private code — chip sequence

All users transmit at same time

User transmission distinguished by chip sequence

TD-CDMA

Time Division Duplex (TDD) method

- Single 35 MHz band
- Divide radio band into 4.4 to 5 MHz RF channels
- RF channel alternates between **UPLINK** times and **DOWNLINK** times
- User allocated half-duplex uplink / downlink time slots on RF channel

TDD advantages

- Asymmetric uplink / downlink times
 - Asymmetric uplink / downlink data rates
 - Dynamic reconfiguration of uplink / downlink times
 - Advantage in multimedia transmission
- Power control
 - All transmission on same frequency band
 - Symmetric uplink / downlink fading and interference

CDMA

Users distinguished by allocated private code — chip sequence

UMTS Network Architecture

User equipment (UE)

- Mobile Station (MS)
- GSM-only UE supported
- UMTS/GSM dual mode UE
 - Can connect to either network
 - Connects via GSM when outside UMTS service area
- Smooth hand-off between UMTS and GSM

UMTS Terrestrial Radio Access Network (UTRAN)

- System of UMTS cells and clusters
- Access network for PLMN
- Mobility management in service area
- Accommodate W-CDMA and new data rates

UTRAN Network Elements

GMS	UMTS	Function
Base Station Subsystem (BSS)	Radio Network System (RNS)	Mobility Management
Base Transceiver System (BTS)	Node B	Cell Control
Base Station Controller (BSC)	Radio Network Controller (RNC)	Cluster Control
	RNCs exchange routing information Offloads handoff coordination from MSC	

UTRAN

- Clusters of cells
- Mobility management

UMTS internal links run ATM

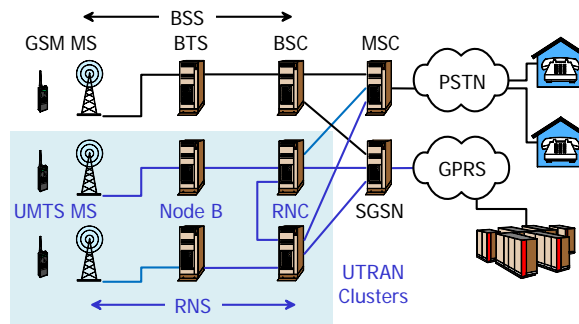

UTMS / GSM Network

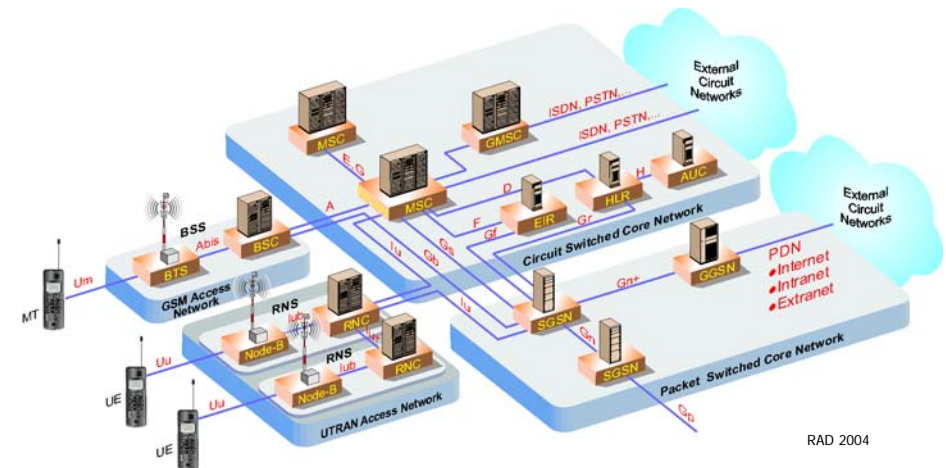

W-CDMA Handoff Types

Intersystem handover

UE switches from W-CDMA to GSM operation
Most complex break before make transition

Hard handover (HHO)

UE switches transmission frequency
Complex break before make transition

Soft handover (SHO)

UE connected to multiple cells (make before break)
UE switches primary connection cell under software control

UE status in cells

Active — cell maintains active connection with UE
Monitored — cell classifies non-active UE as candidate for handoff
Detected — cell aware of non-monitored UE

Cells dynamically reclassify UE based on signal strength

W-CDMA Rake Receiver

Multiple decoders with individual codes

Synchronize to multiple copies of same signal

Multipath mode

Codes differ only in synchronization delays $0, t_1, t_2, t_3$
Adds contributions from all paths
Overcomes multipath interference

Multicode mode

Codes differ in chip sequence
Receive same transmission on different code channels

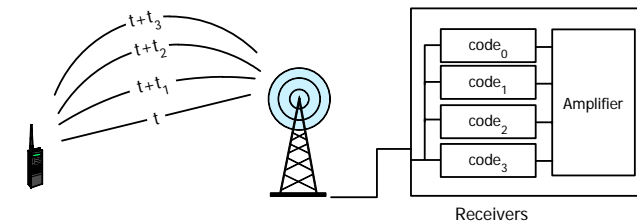

Soft Handoff

Short-time GSM handoff

UE reception better in new cell than old cell
UE allocated frequency pair in new cell
UE closes connection in old cell

Extended-time W-CDMA handoff

UE may be active in multiple cells for extended time period
Rake receiver in multicode mode
UE exchanges same data with multiple cells on multiple codes
Improves data error rate near cell boundary
No need to raise RF power
No increase in interference

Site-Selection Diversity Transmission (SSDT)

UE made active by multiple cells
UE chooses primary cell with feedback information field (FBI)
Non-primary cells list UE as non-active / monitored

Relocation

Serving RNC (SRNC) — RNC-1

Primary Node-B — 1
Monitoring Node-B — 2

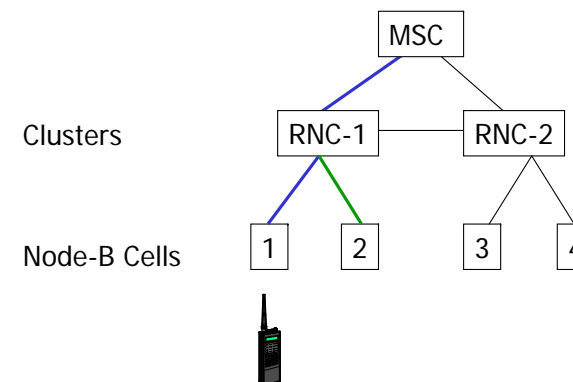

Relocation

Serving RNC (SRNC) — RNC-1

UE relocates to primary Node-B — 2

Monitoring Node-B — 1

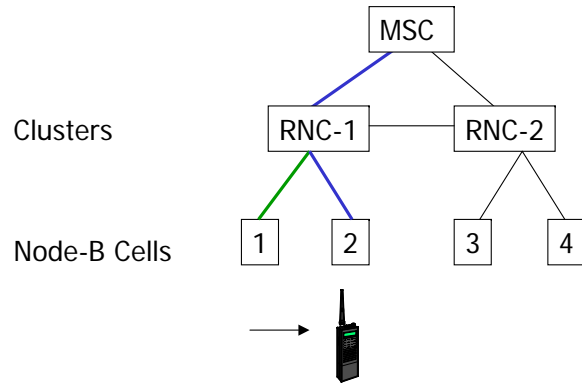

Relocation

Serving RNC (SRNC) — RNC-1

Active Node-B — 2

Relaying RNC (RRNC) — RNC-2

Primary Node-B — 3

Monitoring Node-B — 4

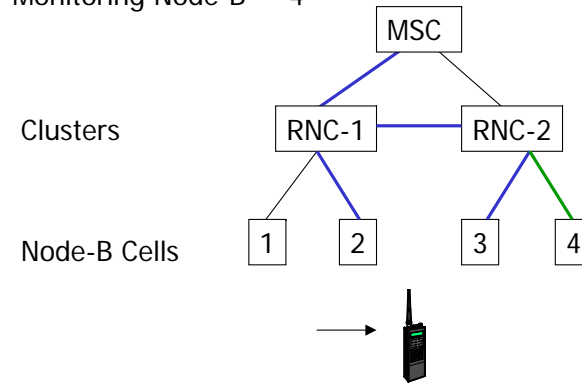

SRNC (RNC-1)
combines data from 2 and 3

Relocation

Serving RNC (SRNC) — RNC-1

No active Node-B

Relaying RNC (RRNC) — RNC-2

Primary Node-Bs — 3 + 4

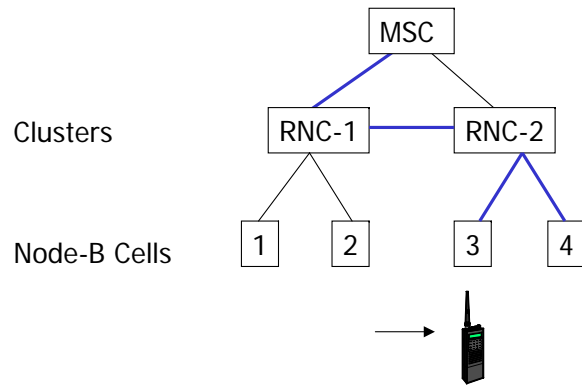

RNC-2
combines data from 3 and 4
SRNC (RNC-1)
receives combined data from RNC-2

Relocation

Serving RNC (RRNC) — RNC-2

Monitoring Node-B — 3

Primary Node-B — 4

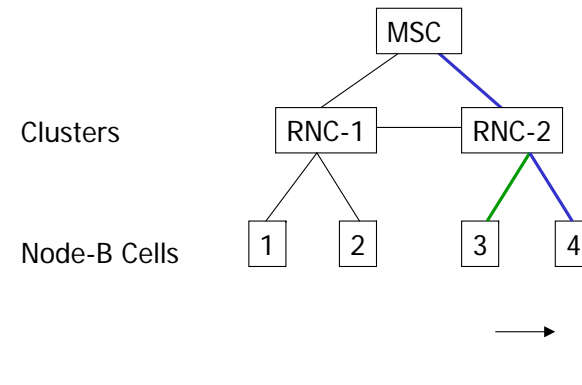

UMTS Protocol Stack

Protocol						Access Awareness	OSI Layer
CC	SS	SMS	GSMS	SM	User Data	Non-Access	3
MM		GMM			RRC	Access	
BMC			PDCP				
RLC				MAC			2
Physical						1	

Non-access stratum (NAS)

Protocols between UE and core network (MSC — PSTN)

Handle connection + traffic

Not aware of radio access method — UTRAN is transparent to NAS

Access stratum (AS)

UE — UTRAN protocols handle connection, traffic, radio access

UTMS Protocols

Circuit Switched Core Protocols	CC	Call control	OSI Layer 3
	SS	Supplementary Services	
	SMS	Short Message Service	
	MM	Mobility Management	
Packet Switched Core Protocols	SM	Session Management	OSI Layer 3
	GSMS	GPRS Short Message Service	
	GMM	GPRS Mobility Management	
System Control	RRC	Radio Resource Control	OSI Layer 2
User Data and Control	BMC	Broadcast / Multicast control	
	PDCP	Packet Data Convergence Protocol	
LLC + MAC Functions	RLC	Radio Link Control	
	MAC	Medium Access Control	

UMTS Chip Rate

Chip rate — RF transitions per second

Fixed at 3.84 Mcps (1 Mcps = 10^6 chips per second)

Chips per symbol

Length of Walsh (downstream) or PN (upstream) code sequence

Spreading factor = 512×2^{-k} chips per symbol

Uses multi-symbol modulation schemes (PSK, QAM, etc)

Baud rate

$3.84 \text{ Mcps} / (512 \times 2^{-k} \text{ chips per symbol}) = 7.5 \times 2^k \text{ k Baud}$

Frame length

Frame transmitted in 10 ms

$3.84 \text{ Mcps} \times 10 \text{ ms} = 38,400 \text{ chips per frame}$

$7.5 \times 2^k \text{ k Baud} \times 10 \text{ ms} = 75 \times 2^k \text{ symbols per frame}$

k	0	1	2	3	4	5	6	7
chips per bit	512	256	128	64	32	16	8	4
Baud rate (k Baud)	7.5	15	30	60	120	240	480	960

Frame Structure

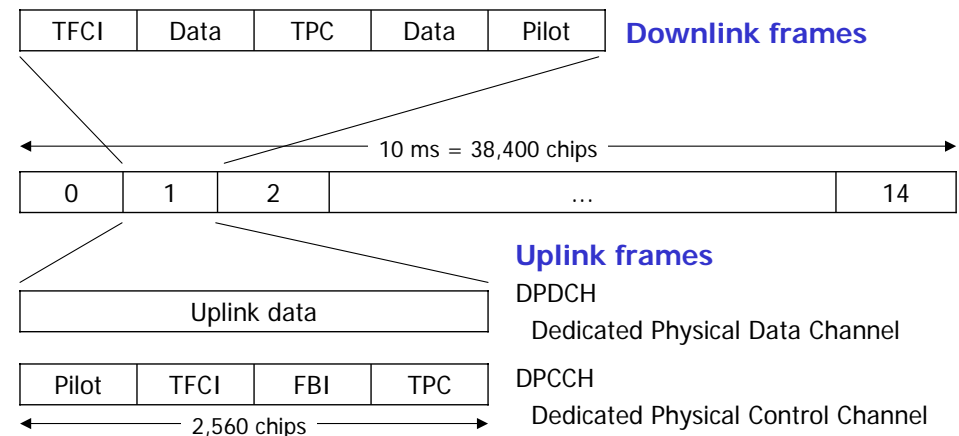

Pilot — synch field

TFCI — transport format combination identifier

TPC — transmission power control (for power level feedback)

FBI — feedback information field (UE chooses cell providing best connection)

Transport Format (TF)

Transport block

MAC layer data / control block

MAC transfers transport block to PHY every 10 ms

Transport block size = number of bits in transport block

Transport block set

1, 2, 4, or 8 transport blocks

Transport block set size = number of bits in transport block set

Transmission Time Interval (TTI)

Time between transfers of transfer block set from MAC to PHY

TTI = 10, 20, 40, 80 ms

Transport Format (TF) reported in TFCI field

TTI

Transport block size

Transport block set size

Information about encoding, error protection, etc

PHY Radio Measurements (Partial List)

Measurement types for UE

Received signal code power (RSCP)

Received signal strength indicator (RSSI)

Received energy per chip divided by power density in band (E_c/N_0)

Block error rate (BLER)

UE transmitted power

UE Rx-Tx time difference

Observed time difference to GSM cell

UE GPS timing of cell frames for UE positioning

Measurement types for UTRAN

Received total wide band power

Signal-to-interference ratio (SIR)

Transmitted carrier power

Transmitted code power

Bit error rate (BER)

Round-trip time (RTT)

MAC Functions

Mapping logical (RLC) channels to transport (MAC) channels

Selection of transport format for transport channel

Identification of UEs on common transport channels

Priority handling

Between data flows of one UE

Dynamic scheduling of UEs

Multiplexing/demultiplexing of higher layer PDUs

To/from transport blocks

To/from physical layer

Traffic volume monitoring

RLC Functions

	Acknowledged Service	Unacknowledged Service	Transparent Service
Segmentation / reassembly (SAR)			
Transfer of user data			
SDU discard			
Concatenation			
Padding			
Encryption			
Sequence number check			
Error correction			
In-sequence PDU delivery			
Duplicate detection			
Flow control			
Protocol error recovery			
QoS			
Unrecoverable error notification			

RRC Functions

Routing of higher layer PDU to layer 2

Cell selection

- Initial cell selection
- Cell reselection
- Measurement control

System information broadcast

Paging

RRC connection with UE

- Establishment, maintenance, release

Radio resources

- Assignment, reconfiguration, and release

Handoff

Security control

QoS

User Functions

PDPC Functions

- Transfer of user data
 - Acknowledged
 - Unacknowledged
 - Transparent
- Compression / decompression for network layer protocol

BMC functions

- Transmission of broadcast / multicast control messages to UE
- SMS cell broadcast services
- Uses RLC unacknowledged mode

User Connection States

GSM	Connected	Dedicated duplex channel between UE and BTS
	Idle	No dedicated channel Control channels (monitoring, paging, broadcast) functions
UMTS	Idle	Similar to GSM Idle
	cell_DCH	Duplex dedicated RRC connection exists in both directions Similar to GSM connected state
	cell_FACH	No dedicated connections Data transfer possible on common (control) channels
	cell_PCH	Similar to Idle Logical RRC connection maintained Fast transition to cell_FACH on upstream data transfer
	URA_PCH	Similar to cell_PCH Cell change does not trigger handoff Data transfer requires paging

Mobility Management (MM)

Initiated by the Network

- TMSI reallocation procedure
- Authentication procedure
- Identification procedure
- MM information procedure
- Abort procedure

Initiated by the Mobile Station

- IMSI attach procedure
- IMSI detach procedure
- Normal location updating procedure
- Periodic updating procedure

GPRS Mobility Management (GMM)

GMM common procedures

- Initiated by network when GMM context established
- P-TMSI (re)allocation
- GPRS authentication and encryption
- GPRS identification
- GPRS information

GMM-specific procedures

- Initiated by network — GPRS detach

Initiated by UE

- GPRS attach GPRS attach
- GPRS detach GPRS detach
- Routing area update
- Service request

Shared Channels

Channel shared among multiple UEs

- UEs request allocation of channel
 - Request in Random Access Channel (RACH)
 - Contention based uplink common channel
- Short term reservation granted by RNC
 - Granted in Forward Access Channel (FACH)
 - Downlink common control channel
- Efficient for low volume bursty delay-tolerant data
- Shared channel not for real time applications

Uplink shared channel

- Common Packet Channel (CPCH)

Downlink shared channel

- Downlink Shared Channel (DSCH)
- High Speed Downlink Shared Channel (HS-DSCH)

High Speed Downlink Packet Access (HSDPA)

Higher data rates for packet data

- Downlink speeds of 1.8, 3.6, 7.2, 14.0 Mbps

HS-DSCH simplified for fast packet data

- Power control and variable chip rate eliminated

Hybrid automatic repeat-request (HARQ)

- LLC layer added between PHY and MAC (not in RLC)
- Incremental redundancy
 - Corrupted packets not discarded
 - Retransmitted packets combined until error-free packet assembled
 - Faster than waiting for uncorrupted retransmitted packet

Fast packet scheduling

- 2 ms scheduling granularity (instead of 10 ms)
- Transmission scheduled to UEs reporting highest power levels

Adaptive Modulation and Coding (AMC)

- Modulation scheme and code rate depend on channel quality

cdma2000

Replacement for IS-95 CDMA (now called cdmaOne)

- Same radio frequencies
- Non-compatible pseudorandom noise (PN) coding scheme
- Higher data rates using improved modulation techniques
- Packet mode data — Mobile IP on voice network (like CDPD)

Evolutionary change from cmdaOne

- Multiple upgrade paths
- Operates in same radio frequencies
 - No new licensing costs for additional radio spectrum
- Backward compatible with cmdaOne
- Minimum risk to existing operators

Third Generation Partnership Project 2 (3GPP2)

- Consortium of manufacturers (www.3gpp2.org)

Standard

- IS-2000

Protocol Architecture

IS-95 — No layered architecture

IS-2000 defines standard OSI layers

Physical layer (Layer 1)

Transmitting and receiving bits over physical medium

Medium access control (MAC) sublayer (Layer 2)

Controls higher layer access to physical medium

Signaling link access control (LAC) sublayer (Layer 2)

LLC reliability of signaling and control messages

Upper layer (Layer 3)

Carries out overall control of IS-2000 system

IS-2000 Spreading Rates

1xRTT

Same 1.25 MHz radio channel as IS-95

Double IS-95 chip rate → 128 chips per bit

Double users → 128 users per channel

RF compatible with IS-95 in same cell

Uses codes orthogonal to IS-95 codes

1xEV-DO (data only)

Physical layer different from 1xRTT

Higher data rates (3.1 Mbps forward / 1.8 Mbps reverse)

No increase in voice capacity

3x (3xRTT)

Uses 3.75-MHz radio channels

Direct Spread (DS) — one 3.75-MHz RF carrier

Multicarrier (MC) — spreads data among 3 IS-95 1.25 MHz channels

Next Generation Networks (NGN)

ITU initiative for long-term network planning

Standardizes current view of technology convergence

NGN definition

Packet-based network

Provide telecommunication services

Use multiple broadband QoS-enabled transport technologies

Service functions independent of transport technology

Enables unfettered user choice of access to

Networks

Competing service providers and/or services

Supports generalized **MOBILITY**

Allow consistent and ubiquitous provision of services to users

From ITU-T Recommendation Y.2001 (12/2004)

NGN in the Marketplace

Mobility

Basic feature of contemporary workflow

Important source of profit for telecommunications industry

Convergence

Workflow ⇒ universal access to services through any networks

Multiple incompatible networks ⇒ market share + profits

Where do technologies converge?

Most systems can interface service to infrastructure with TCP/IP

Inherently digital services → internet

Inherently analog services → A/D + compression → internet

NGN generally means all-IP network

All services defined to work over IP

All infrastructures defined to work below IP

Problem — QoS, reliability, mobility not natural in IP

NGN Visions

Migration of all existing voice networks

Most voice infrastructure is still hierarchical

DS-0 circuit switching

High speed trunk lines organized in tree topology among ESSs

Isochronous circuit mode operation natural for voice traffic

NGN requires transforming voice networks to VoIP

Migration of local access from voice to DSL

Single fast digital interface to doorstep

Fiber to the door an expensive dream

Migration to flexible metropolitan area networks (MAN)

"Carrier Ethernet" and cellular broadband (WiMAX) in urban areas

Improvement of QoS in IP networks

Multiprotocol Label Switching (MPLS)

Session Initiation Protocol (SIP)

4G Cellular

Initial planning for 4th generation cellular systems

ITU working group planning IMT-2000 → IMT-Advanced

Conceived as network supporting mobility — not telephones + data

Convergence with NGN

4G objectives

Higher network capacity than 3G

Spectral efficiency (high bps / Hz and bps / Hz /site)

100 Mbps for moving client and 1 Gbps for stationary client

100 Mbps between any two points in world

Smooth handoff across heterogeneous networks

Global roaming across multiple networks

QoS for multimedia support — audio, HDTV, etc

Interoperability with existing wireless standards

All IPv6 packet switched network — eliminate circuit mode entirely